

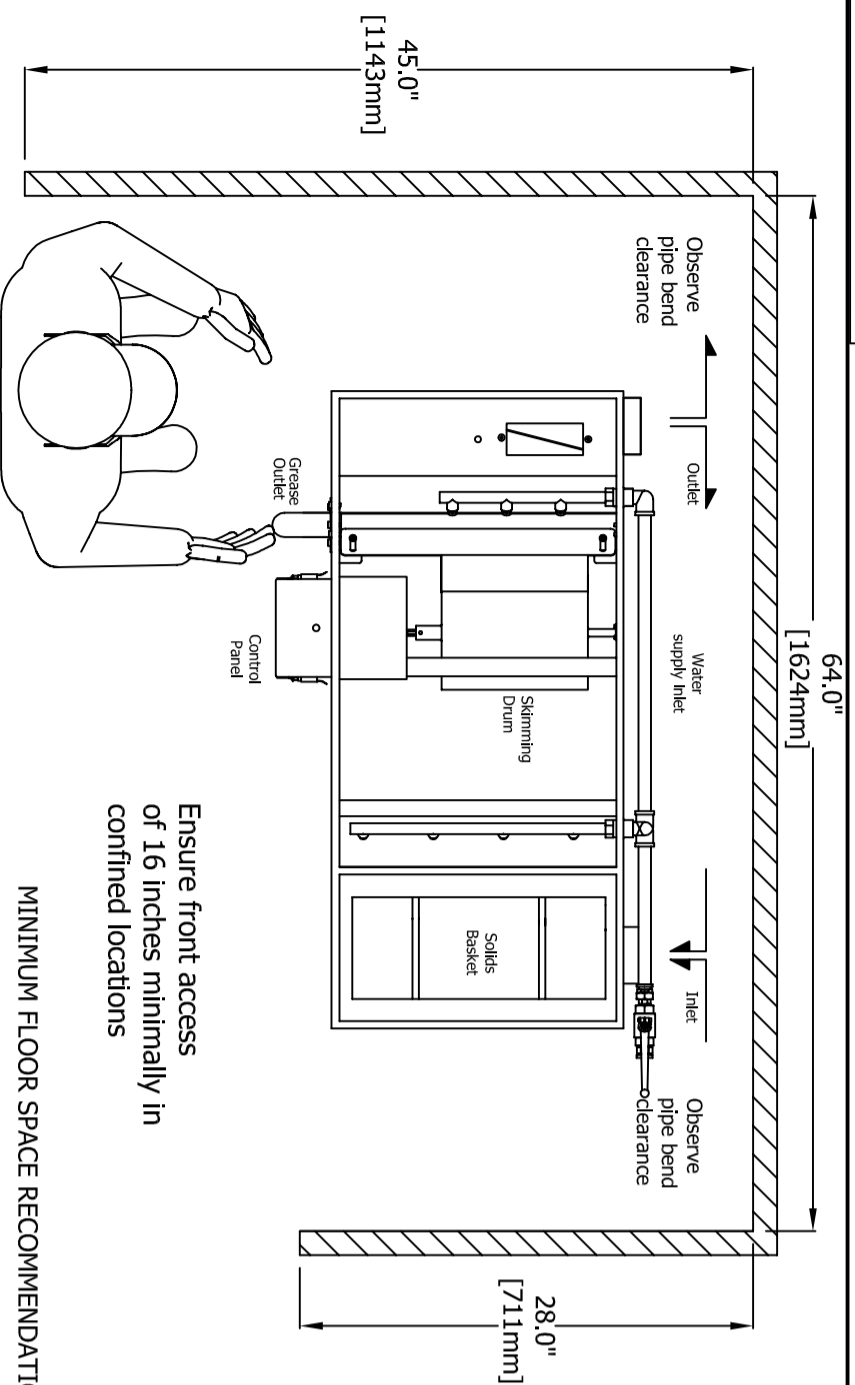

GGX50 Grease Guardian Installation Details



Ensure front access
of 16 inches minimally in
confined locations

MINIMUM FLOOR SPACE RECOMMENDATION

KEY INSTALLATION NOTES:

This unit is to be installed free standing normally at a lower level than the kitchen floor.
Allow for the minimum dimensions shown.
Keep outlet piping at a fall of $\frac{1}{8}$ " per foot (1:40).
Use adjustable rubber pipe connectors as supplied.
Only switch on after filling system to the required level
Refer to manual for full installation details.

SPECIFICATION:

Grease Guardian Model GGX50:
Automatic grease removal unit, 16 gauge fully welded 304 stainless steel tank, stainless steel internal baffle plate, fully sealed air tight stainless steel lid and robust stainless steel clamps, stainless steel vertical lift solids strainer basket for easy disposal of solids, easy fit pipe couplings supplied, 50 gallons per minute flowrate, and skimming rate of 20 pounds per hour. The GGX50 is supplied with a rotating grease skimming drum with a manually operated internal wash system for the wiper blade and scum dispersion, integral gas trap, totally enclosed geared drive unit, 600 watt immersion heater with self regulating safety control, programmable controller with interface, energy saving mode and visual alerts. The GGX50 is suitable for floor and shelf type mounting. 3 year warranty as standard.

Electrical Details

GGX50 110VAc, 635 Watts, 5, 8A

www.greaseguardianUSA.com

GGX50 RG



GGX50 Grease Guardian Standard Specification

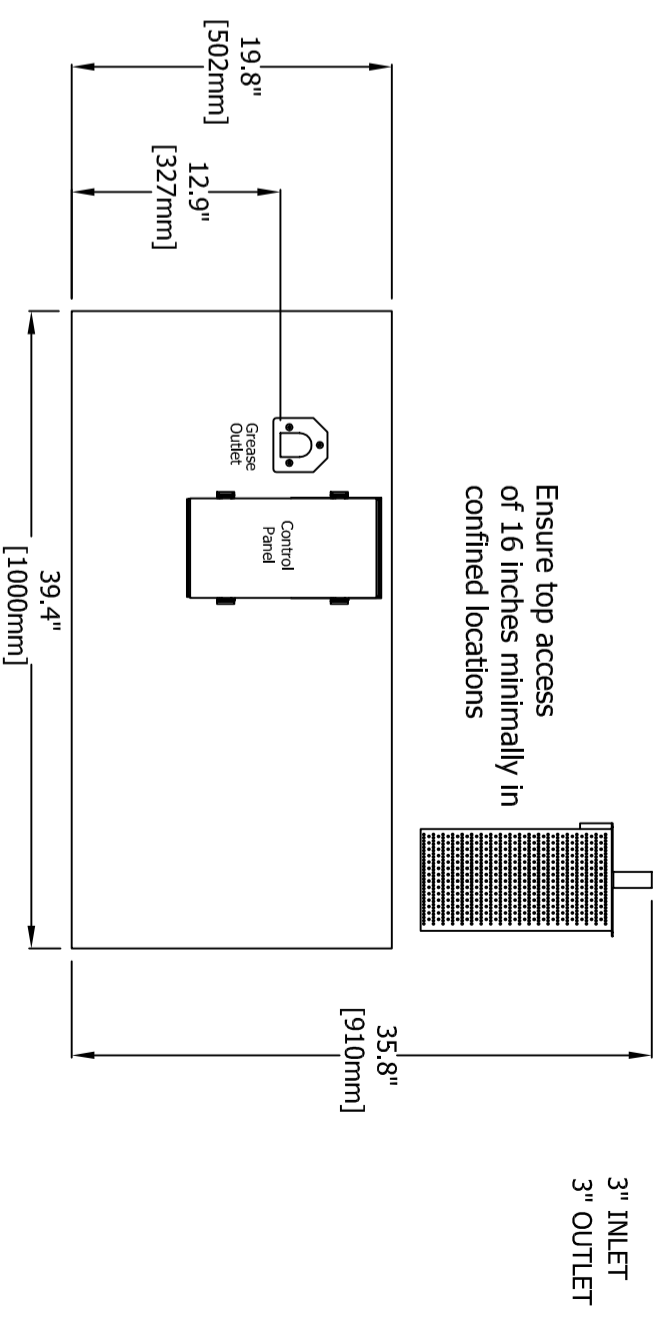

Ensure top access
of 16 inches minimally in
confined locations

FRONT VIEW

GREASE GUARDIAN X STANDARD FEATURES:

- 3 Year Guarantee
- Fully Automatic Grease Removal Unit (AGRU)
- 16 gauge 304 stainless steel welded tank
- Fully sealed air tight lid
- PLC/HMI automatic controller
- Energy saving mode
- Skimming drum with manual spray bar wash
- Wash-water conditioning system
- Lift-out solids basket
- Grease Guardian World asset management

SIDE ELEVATION

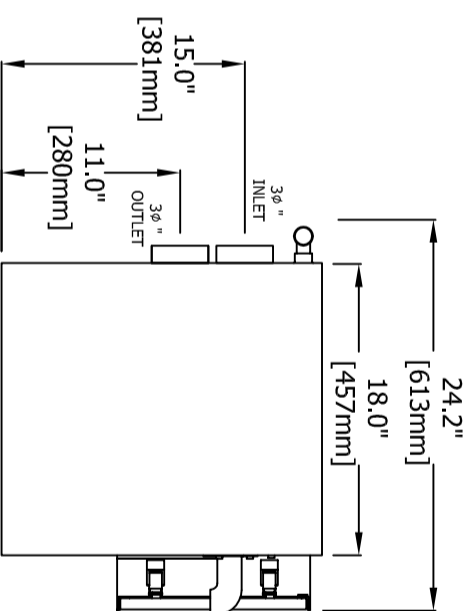

Ensure front
access
of 16 inches
minimally in
confined
locations

TECHNICAL DATA

Weight _____ 190 pounds
Exterior Materials _____ 16 gauge AISI304 Stainless Steel
Interior Materials _____ AISI304 Stainless Steel & Acetal Components
Maximum Flow Rate _____ 50 GPM
Lift-out screen basket capacity _____ 2.5 gallons
Skimming Rate _____ 20 pounds per hour
Grease Retention Capacity _____ 100+ pounds
Wash water system operation requirements (minimum) _____ 12gpm/43.5psi (0.75litres/s@3bar)
Programming/Control _____ 7day, 24hr multi-function PLC
Electrical Load _____ 110VAC, 635W, 5.8A

Copyright Jan 2015 FM Environmental Ltd. All Rights Reserved. Specification subject to change without notice

GGX50 RG